

5.18.32 Climbing wood »Eagle owl«



*Description:*

Climbing wood »Eagle owl«

1 Play tower 3-cornered with pitched roof

1.5/1.5/1.5 m; Ph = 2.0 m

with side trim

2 Posts as tree prongs shaped

1 Window opening with stainless steel grid

1 Slanted net entrance

0.75 x 2.0 m; MW 25/25 cm

1 Tubular net

l = 3.0 m; 0.8 x 0.8 m

1 End post

w = 1.2 m; h = 2.0 m

5 Climbing posts

h = 3.0 – 3.5 m

1 Triangle net

1.0/1.6/1.85 m; MW 30/30 cm

2 Balancing beams with support rope

l ~ 1.5 m / 2.0 m

1 Triangle net

1.9/2.6/2.7 m; MW 30/30 cm

1 Balancing rope (thick); l = 2.8 m

1 Climbing net ascent; l = 2.5 m

1 Hanging rope; l = 2.5 m

5 Connecting beams

l ~ 2.0 – 3.3 m

colour: robinia bright

*optional: Sculpture »Eagle owl«*

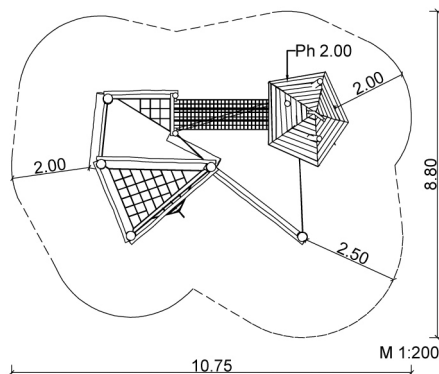

**Gr.** 5 – Multi units

6 – 12 years

~ 20 children

2.00 m

from 5

75.00 m<sup>2</sup>

about 2190 kg; biggest about 700 kg

2 installers at 20 h; + equipment

13

~ 1.80 m<sup>3</sup>

SIK-Holz quality inspection according to DIN EN 1176 at the factory by a qualified playground inspector.



master enterprise for wood sculpture  
© SIK-Holzgestaltungs GmbH

5.18.32 Climbing wood »Eagle owl«

