

ASSEMBLING INSTRUCTION

4.8 Carousel (generally)

Scope of delivery

Amount	Denomination	Measure
1	carousel plate with sculpture	150 kg
1	ground anchor with carousel mechanism	50 kg
Sum	approx.	200 kg

All weights are approximate. The heaviest component is highlighted in bold.

Tools

- spade, shovel, tape measure, hammer and spirit level
- socket wrench 17 / 19 mm, screwdriver with insert Torx Bit (TX 10-30)
- 2 persons (2 installers at 4 h)
- wheel loader with palette fork
- approx. concrete 0.2 m³ C 20/25

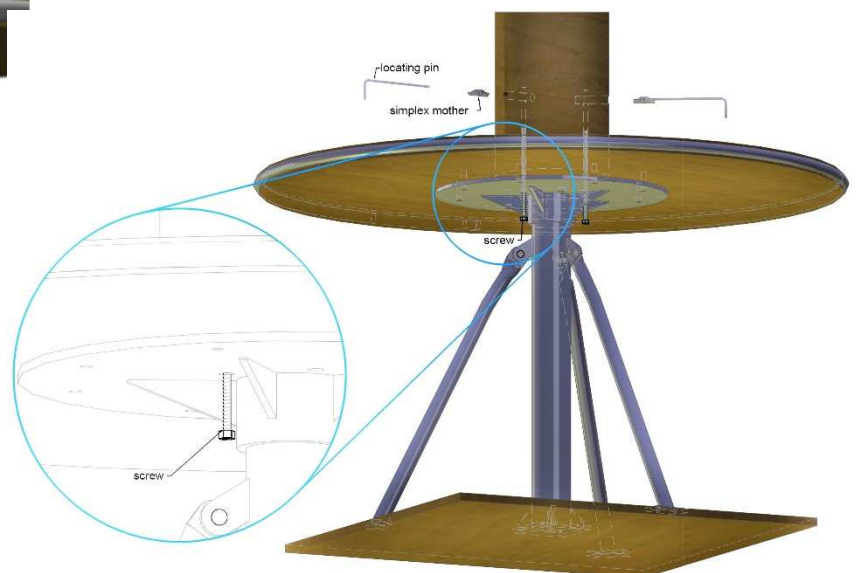
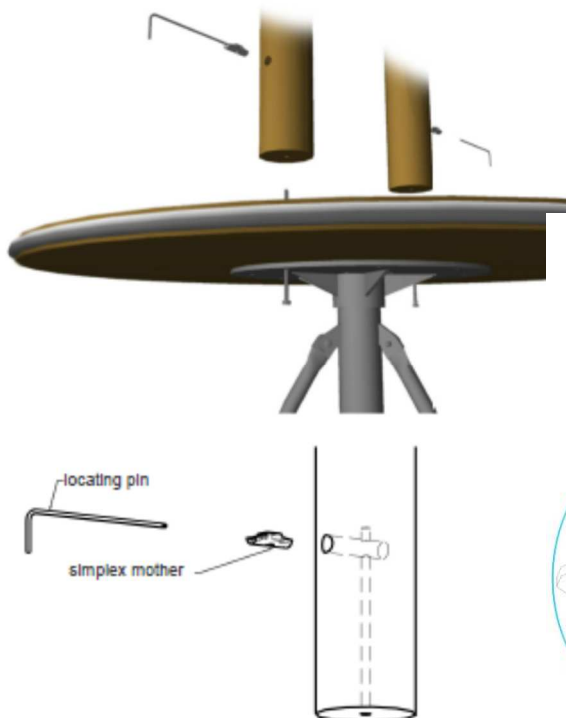

Assembling

- First, the playing surface (security area) should be measured, set the point (height) and the start point can be determined.
- Digging hole depending on the section for the play unit and depending on the ground conditions a drainage layer, for example gravel layer 10 cm in order to prevent stagnant moisture.
- Lift the ground anchor into the prepared hole, to adjust by means of spirit level and make them solid.
- Manufacturing the foundation according to drawing.
- **Note: The freedom of movement for mounting the carousel plate is observed (note photo).**
- Now the carousel plate is aligned on the carousel mechanism and bolted together. **Pay attention to the 2 screws which have to be screwed into the sculpture from below through the carousel mechanism (note illustration, locating pin and simplex mother).**
- Please note: The 2 drill-holes in sculpture will be covered at the end of the assembly with the enclosed caps.
- After 3-5 days of curing time, which fill game surface again and clear the game surface for playing.
- Transportation braces and installation damage are to be removed after installation on site, grind and paint damaged areas.
- **Notice:** concrete needs about 28 days in order completely to harden.

ASSEMBLING INSTRUCTION

Security guidelines

During assembly and transport on site, play towers and/or attachment parts must always be adequately secured, either through technology or through attached transportation bracing.

Required safety areas/ falling space around equipment are indicated on the installation drawings.

Playground equipment with a potential height of fall of more than 600 mm and/or a forced movement require an impact attenuating/ shock-absorbing surface in the whole impact area below them according to the **EN 1176 and EN 1177**. (Non-shock-absorbing undergrounds are for example without limitation: bricks, stones, concrete, bitumen and wood.)

Preventive maintenance instructions

An operational check of the equipment must be carried out 2 weeks after installation. Here the main attention should be paid to tight screw joints and stability. In general the equipment should be checked on a regular basis. A visual routine inspection should be carried out on a weekly basis. An operative inspection should be performed every 1–3 months and the general or main inspection has to happen on an annual basis. We recommend to check stability of posts once a year and to expose foundations, let them dry and to repaint them also below ground level above the foundation with a solvent free glaze. **(Further information concerning maintenance can be found in our *Checklist for Maintenance/ Inspection*, in our *General Maintenance Notes* and also in our catalogues, as well as on our website www.sik-holz.de/en)**

Rev. 11.2019	Page 2 von 2	MASTER ENTERPRISE OF WOODCARVING HANDICRAFTS / © SIK-HOLZGESTALTUNGS GMBH	
FURTHER INFORMATIONS: SIK-HOLZGESTALTUNGS GMBH, LANGENLIPSDORF 54 A, D-14913 NIEDERGÖRSDORF; +49(0)33742-7990; WWW.SIK-HOLZ.DE ; INFO@SIK-HOLZ.DE			