

springer ""

detail fitting springer

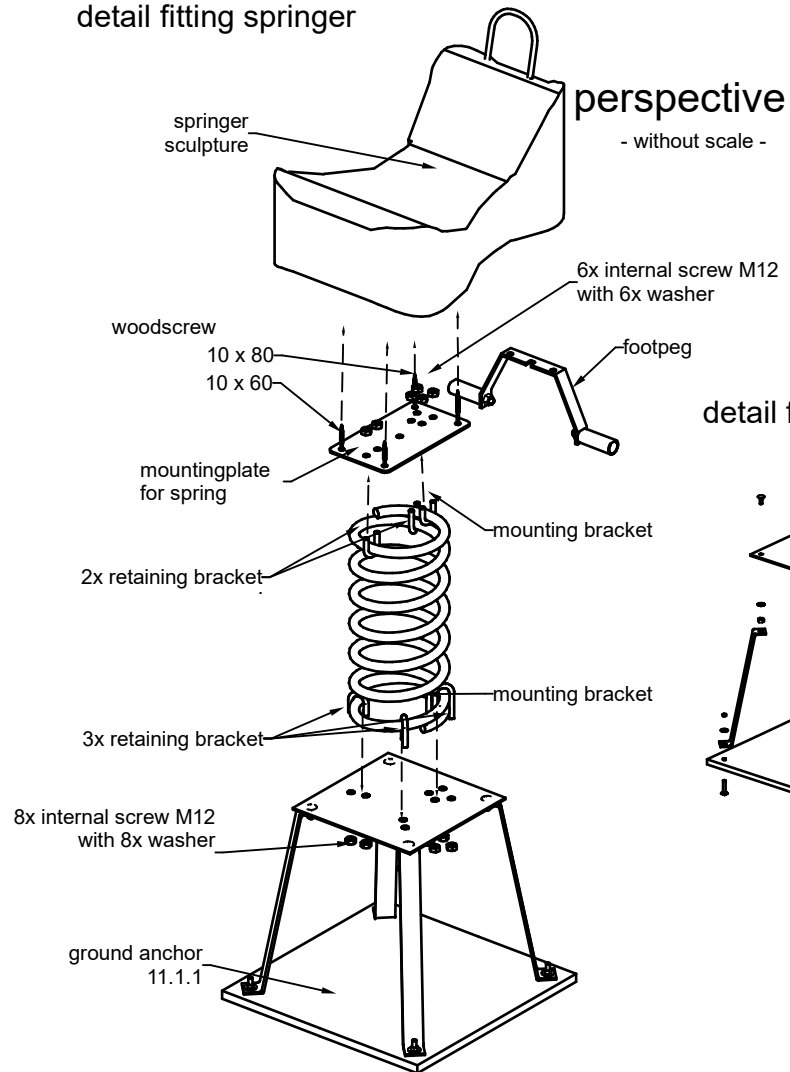

detail fitting ground anchor 11.1.1

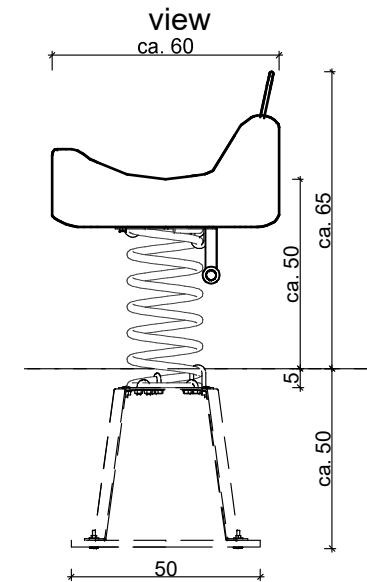
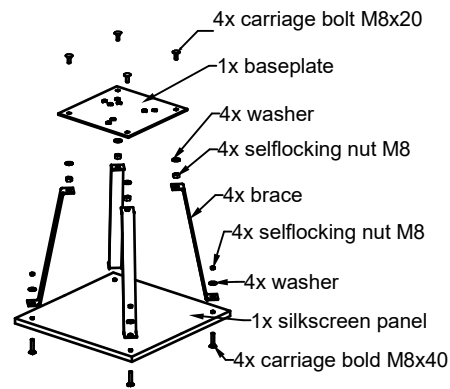

grounding detail - without scale - ground anchor 11.1.1

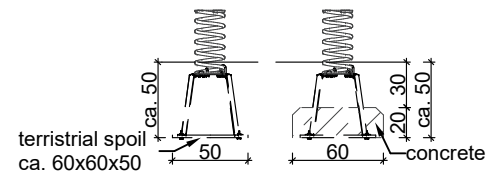

Gravel must follow the installation of the foundation, for example in playsand, bark mulch and wood fiber mulch. In the case of natural soil or for example grass no foundation required.

topview with minimum safety area scale 1:100

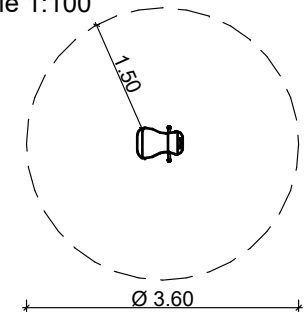

project:	springer "" (with a spring)	scale:	A4; 1:20	page:	1/1
address:		date:	14.05.2018		
editor:		<p>Master enterprise of woodcarving handicrafts © SIK-Holzgestaltungs GmbH</p>			
article ID:					
project ID:	assembly				

ASSEMBLING INSTRUCTION

1.3–1.29 Springer / generally

Scope of delivery

Amount	Denomination	Measure
1	sculpture with mounted spring	45 kg
1	ground anchor (assembly set)	15 kg
Sum		approx. 60 kg

All weights are approximate. The heaviest component is highlighted in bold.

Tools

- spade, shovel, tape measure, spirit level
- socket wrench 13 / 17 / 19 mm
- 1 person (1 installer at 1.5 h)
- approx. concrete 0.1 m³ C 20/25

Assembling

- Parts of the springer according to the instruction's assembly.
- Determine the foundation position according to plan. **Measures due by the client/customer check.**
- Digging hole for the ground anchor and depending on the ground conditions, a drainage layer, for example gravel layer 10 cm in order to prevent stagnant moisture.
- Note the installation depth and viewing direction of the springer
- Lift the springer with ground anchor into the prepared hole, to adjust by means of spirit level.
- After everything is assembled and aligned, the foundation according to the drawing can be properly completed.
- After 3–5 days of curing time which fill game surface again.
- Transportation braces and installation damage are to be removed after installation on site, grind and paint damaged areas.
- **Notice:** concrete needs about 28 days in order completely to harden.

Security guidelines

During assembly and transport on site, play towers and/or attachment parts must always be adequately secured, either through technology or through attached transportation bracing.

Required safety areas/ falling space around equipment are indicated on the installation drawings.

Playground equipment with a potential height of fall of more than 600 mm and/or a forced movement require an impact attenuating/ shock-absorbing surface in the whole impact area below them according to the **EN 1176 and EN 1177**. (Non-shock-absorbing undergrounds are for example without limitation: bricks, stones, concrete, bitumen and wood.)

Preventive maintenance instructions

An operational check of the equipment must be carried out 2 weeks after installation. Here the main attention should be paid to tight screw joints and stability. In general the equipment should be checked on a regular basis. A visual routine inspection should be carried out on a weekly basis. An operative inspection should be performed every 1–3 months and the general or main inspection has to happen on an annual basis.

We recommend to check stability of posts once a year and to expose foundations, let them dry and to repaint them also below ground level above the foundation with a solvent free glaze. **(Further information concerning maintenance can be found in our *Checklist for Maintenance/ Inspection*, in our *General Maintenance Notes* and also in our catalogues, as well as on our website www.sik-holz.de/en)**

ASSEMBLING INSTRUCTION

Detail drawing

Assembly and alignment
of the ground anchor at springer

(top view)

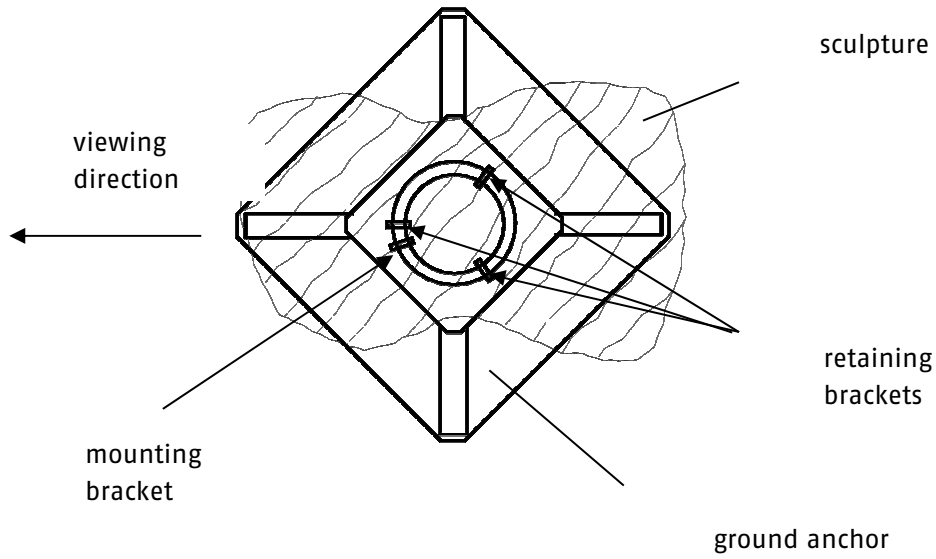

(bottom view)

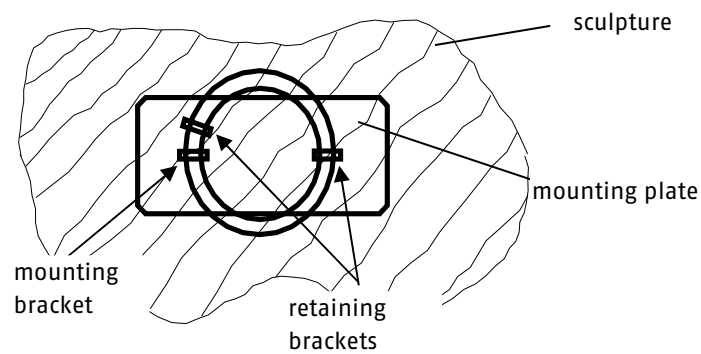

Detail brackets

